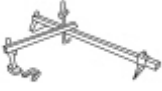
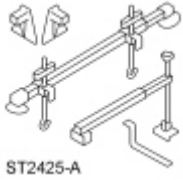

## Oil Filter Adapter

### Special Tool(s)

 <p>ST1603-A</p>	Lifting Bracket, Engine (2 required) 303-D087 (D93P-6001-A1) or equivalent
 <p>ST2176-B</p>	Support Bar, Engine 303-F070
 <p>ST2425-A</p>	Support Bar, Engine 303-F072

### Material

Item	Specification
Motorcraft® Metal Surface Prep ZC-31-A	—
Motorcraft® SAE 5W-50 Full Synthetic Motor Oil XO-5W50-QGT or equivalent	WSS-M2C931-B

### Removal

1. With the vehicle in NEUTRAL, position it on a hoist. For additional information, refer to [Section 100-02](#).
2. Remove the 2 dash boot nuts.
3. **NOTE:** Use a steering wheel holding device (such as Hunter® 28-75-1 or equivalent).

Using a suitable holding device, hold the steering wheel in the straight-ahead position.

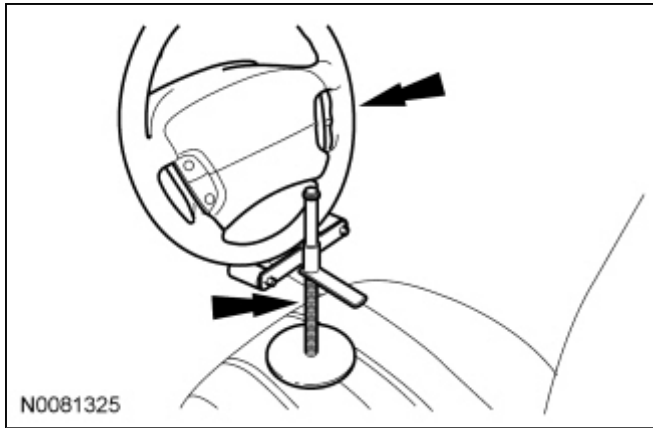

4. Remove the 4 nuts and the strut tower cross brace.

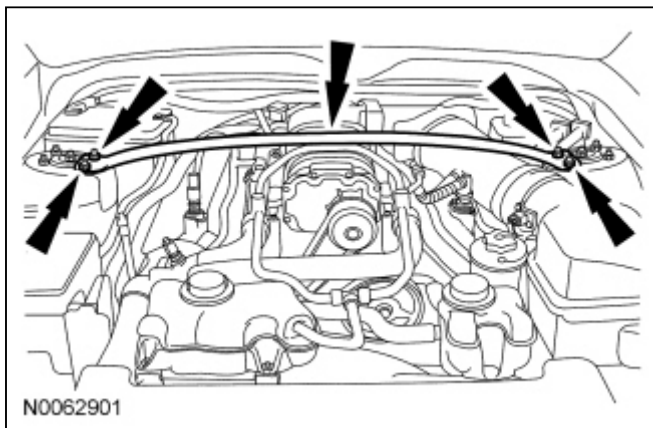

5. Drain the engine cooling system. For additional information, refer to [Section 303-03A](#).
6. Remove the battery and tray. For additional information, refer to [Section 414-01](#).
7. Remove the Air Cleaner (ACL) outlet pipe. For additional information, refer to [Section 303-12](#).
8. Remove the oil cooler. For additional information, refer to [Engine Lubrication Components — Exploded View](#) and [Oil Cooler](#) in this section.
9. Install the Engine Lifting Bracket.

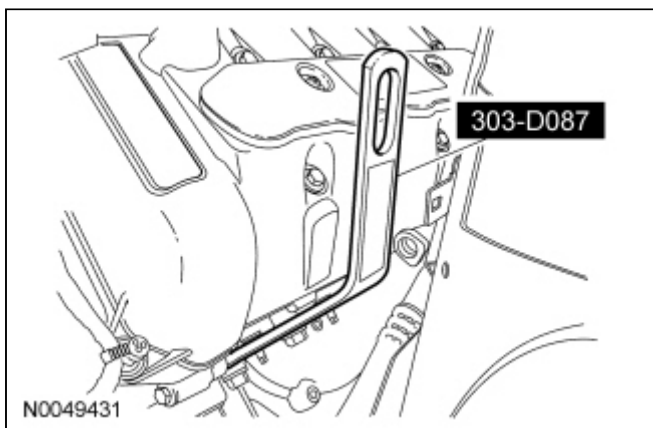

10. Install the Engine Lifting Bracket.

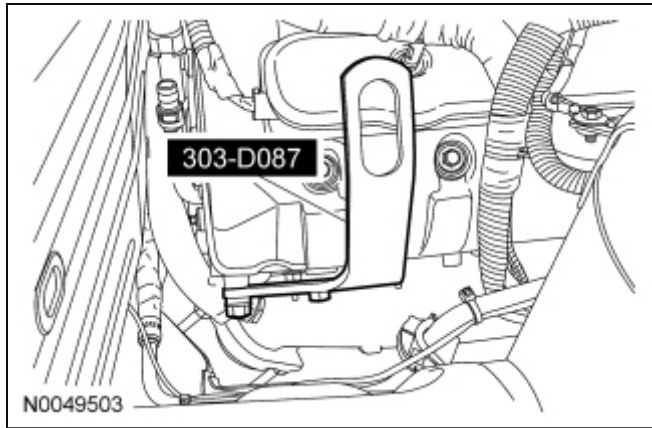

11. Remove the LH and RH engine support insulator nuts.
12. **NOTE:** The heavy duty Engine Support Bar (303-F070) must be used with the light duty Engine Support Bar (303-F072). This will provide enough clearance between the Supercharger (SC) and the Engine Support Bar, and enough clearance between the draw screw and the vehicle hood.

Install the Engine Support Bars and raise the engine.

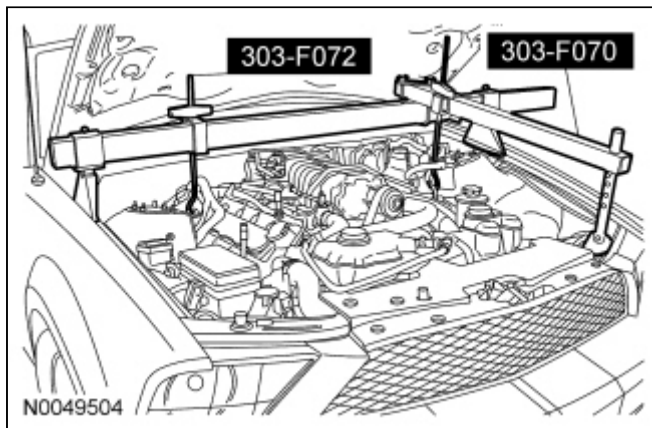

13. Drain the engine oil.
  - Tighten the drain plug to 26 Nm (19 lb-ft).
14. Remove and discard the engine oil filter.
15. Position a suitable adjustable jackstand under the subframe.
16. **NOTICE:** Do not allow the steering wheel to rotate while the steering column intermediate shaft is disconnected or damage to the clockspring can result. If there is evidence that the wheel has rotated, the clockspring must be removed and recentered. For additional information, refer to [Section 501-20B](#).

Remove the upper bolt from the intermediate steering shaft.

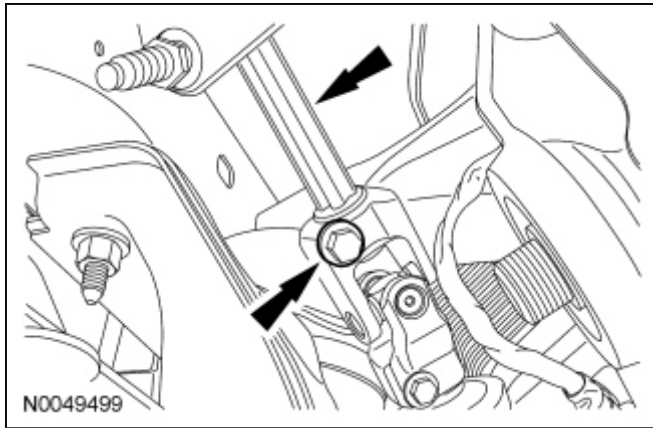

17. Mark the position of the 4 subframe nuts and 4 subframe bolts for referencing during assembly.

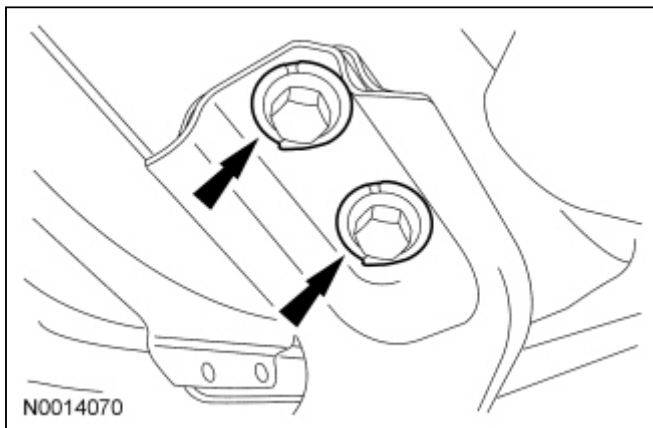

18. Remove the 4 subframe nuts and 4 subframe bolts.
19. Using the adjustable jackstand, lower the subframe 50 mm (1.96 in).
20. Remove the 4 bolts and the LH engine support bracket.
21. Remove the 2 coolant tube assembly-to-oil filter adapter bolts.
22. Disconnect the 2 coolant hoses from the oil filter adapter.
23. Disconnect the Engine Oil Pressure (EOP) switch electrical connector and the 2 wiring harness pin-type retainers.
24. Remove the 8 bolts and the oil filter adapter.
  - Discard the gasket.

## Installation

1. **NOTE:** Clean and inspect the sealing surfaces with metal surface prep. Follow the directions on the packaging.

Using a new gasket, install the oil filter adapter and the 8 bolts.

- Tighten in the sequence shown:
  - Bolts 1 through 6 to 25 Nm (18 lb-ft).
  - Bolts 7 and 8 to 50 Nm (37 lb-ft).

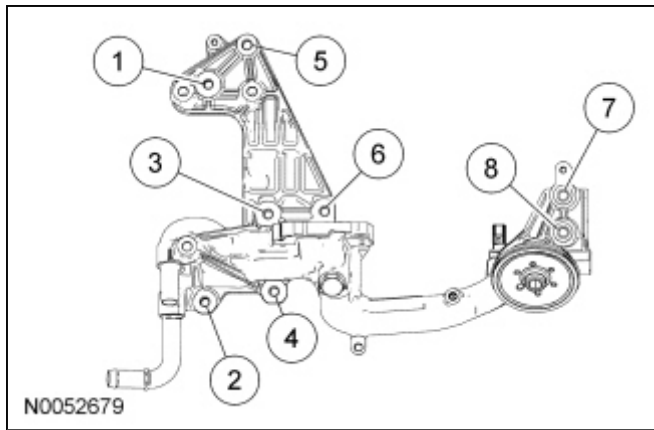

2. Connect the [EOP](#) switch electrical connector and the 2 wiring harness pin-type retainers.
3. Connect the 2 coolant hoses to the oil filter adapter.
4. Install the 2 coolant tube assembly-to-oil filter adapter bolts.
  - Tighten to 10 Nm (89 lb-in).
5. Install the LH engine support bracket and the 4 bolts.
  - Tighten to 80 Nm (59 lb-ft).
6. Using the adjustable jackstand, raise the subframe.
7. **NOTICE:** Do not allow the steering wheel to rotate while the steering column intermediate shaft is disconnected or damage to the clockspring can result. If there is evidence that the wheel has rotated, the clockspring must be removed and recentered. For additional information, refer to [Section 501-20B](#).

Position the intermediate steering shaft and install the upper bolt.

- Tighten to 47 Nm (35 lb-ft).

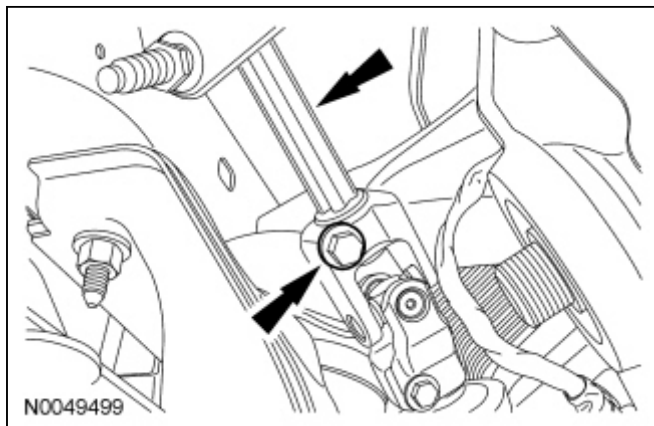

8. **NOTE:** Do not tighten the subframe nuts and bolts at this time.

Install the 4 subframe nuts and 4 subframe bolts.

9. Align the subframe nuts and bolts with the reference marks made during removal.
  - Tighten the nuts to 115 Nm (85 lb-ft).
  - Tighten the bolts to 115 Nm (85 lb-ft).

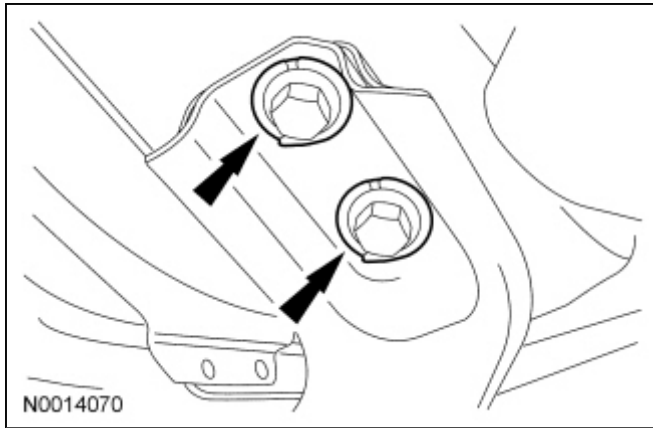

10. Install a new engine oil filter.
  - Lubricate the oil filter gasket with clean engine oil and tighten until the seal makes contact.
  - Using a suitable oil filter strap wrench, tighten the filter an additional 270 degrees.
11. Using the Engine Support Bars, lower the engine onto the engine support insulators.

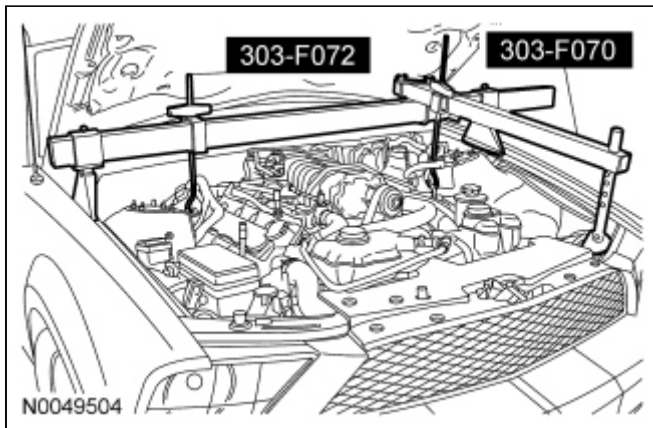

12. Install the LH and RH engine support insulator nuts.
  - Tighten to 63 Nm (46 lb-ft).
13. Install the oil cooler. For additional information, refer to [Engine Lubrication Components — Exploded View](#) and [Oil Cooler](#) in this section.
14. Install the [ACL](#) outlet pipe. For additional information, refer to [Section 303-12](#).
15. Install the battery and tray. For additional information, refer to [Section 414-01](#).
16. Install the strut tower cross brace and the 4 nuts.
  - Tighten to 35 Nm (26 lb-ft).

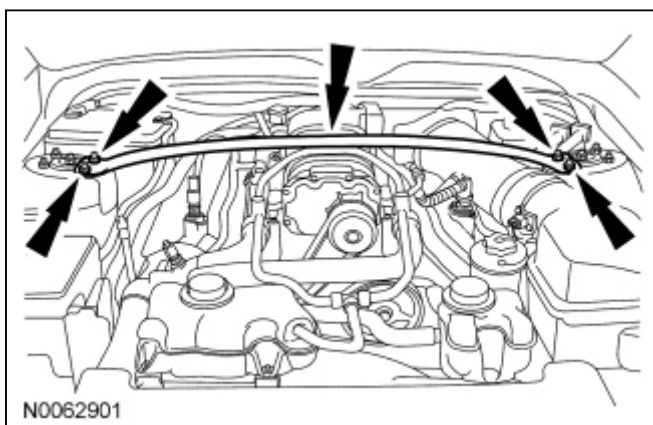

17. Install the dash boot and the 2 nuts.
    - Tighten to 9 Nm (80 lb-in).
  18. Fill the engine with clean engine oil.
  19. Fill and bleed the engine cooling system. For additional information, refer to [Section 303-03A](#).
-